

ALVARO F. M. AZEVEDO; JOAQUIM A. FIGUEIRAS

Modelo de Análise de Estruturas Planas de Betão Armado

Transparências apresentadas por Alvaro Azevedo no

1º Encontro Nacional sobre Análise Experimental de Tensões

LNEC - Lisboa - Portugal

Novembro de 1986

MODELO DE ANALISE DE ESTRUTURAS PLANAS DE BETAO ARMADO

-- ESTADO PLANO DE TENSAO

-- METODO DOS ELEMENTOS FINITOS

Elementos isoparametricos de 8 nos

Elementos lineares de 2 nos

-- COMPORTAMENTO NAO LINEAR

Betao : criterio de cedencia-fractura-esmagamento

Aco : comportamento bilinear

-- METODO INCREMENTAL E ITERATIVO (Newton-Raphson)

-- COMPARACAO ENTRE ENSAIOS EXPERIMENTAIS E MOD. MAT.

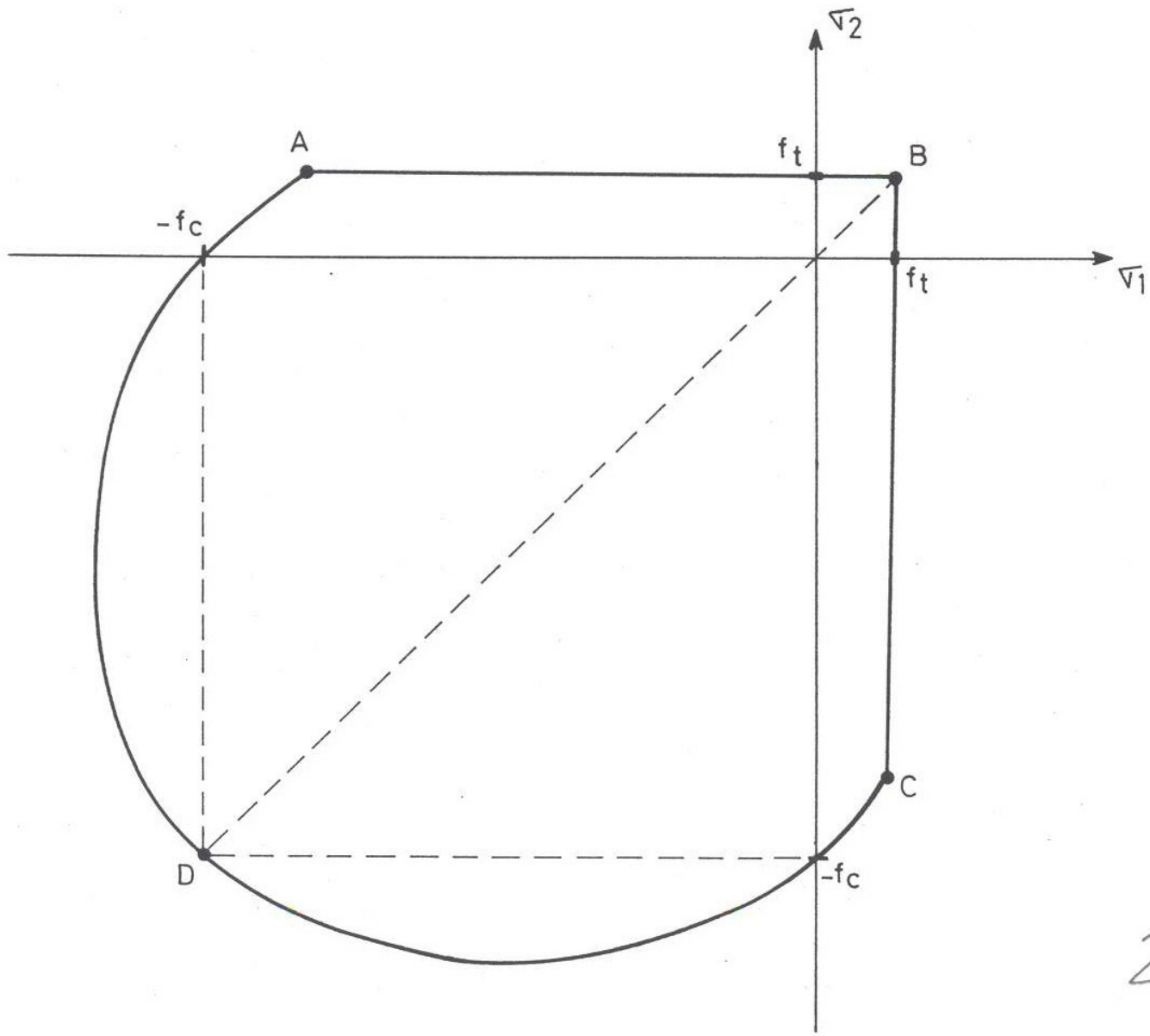

2

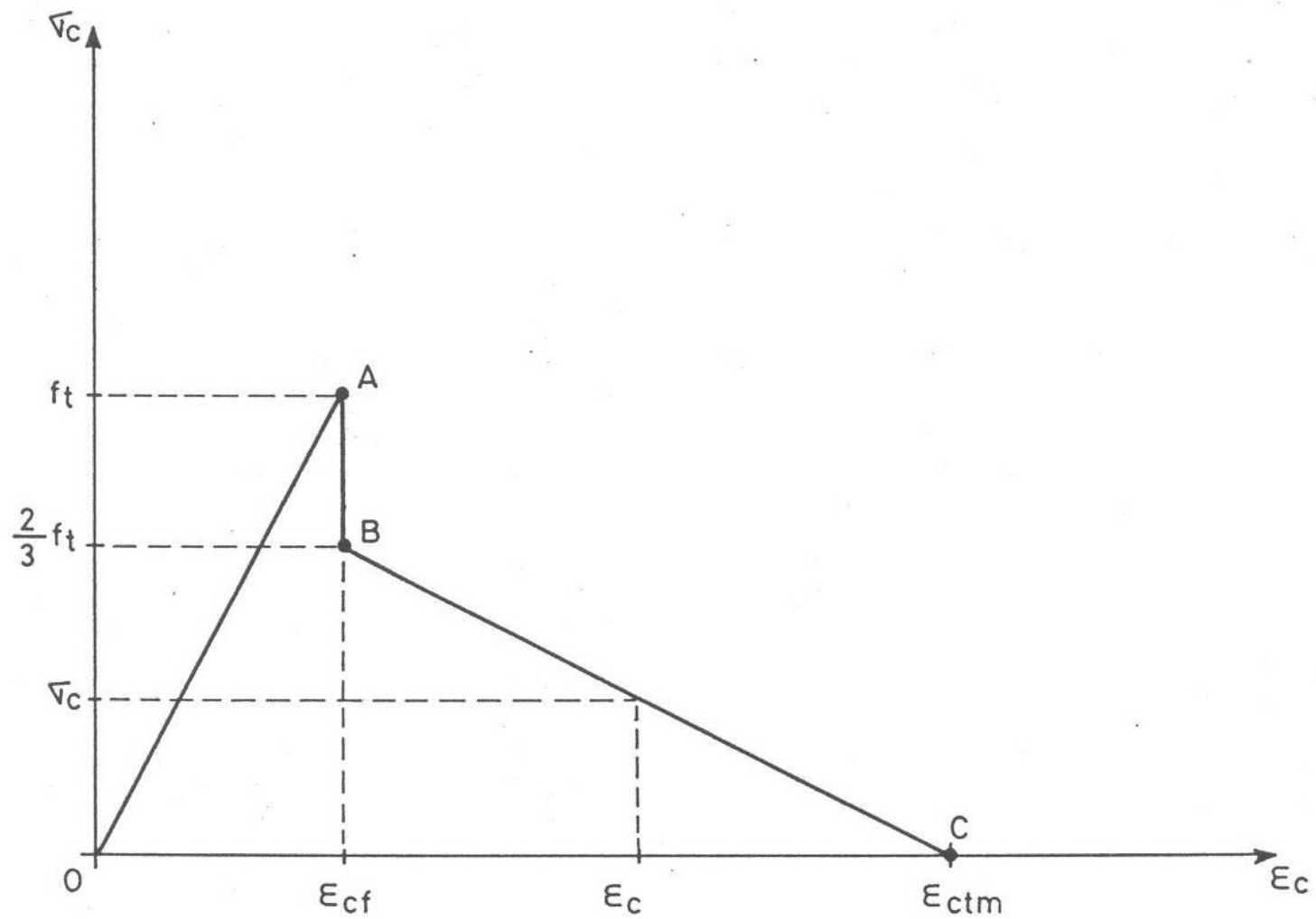

3

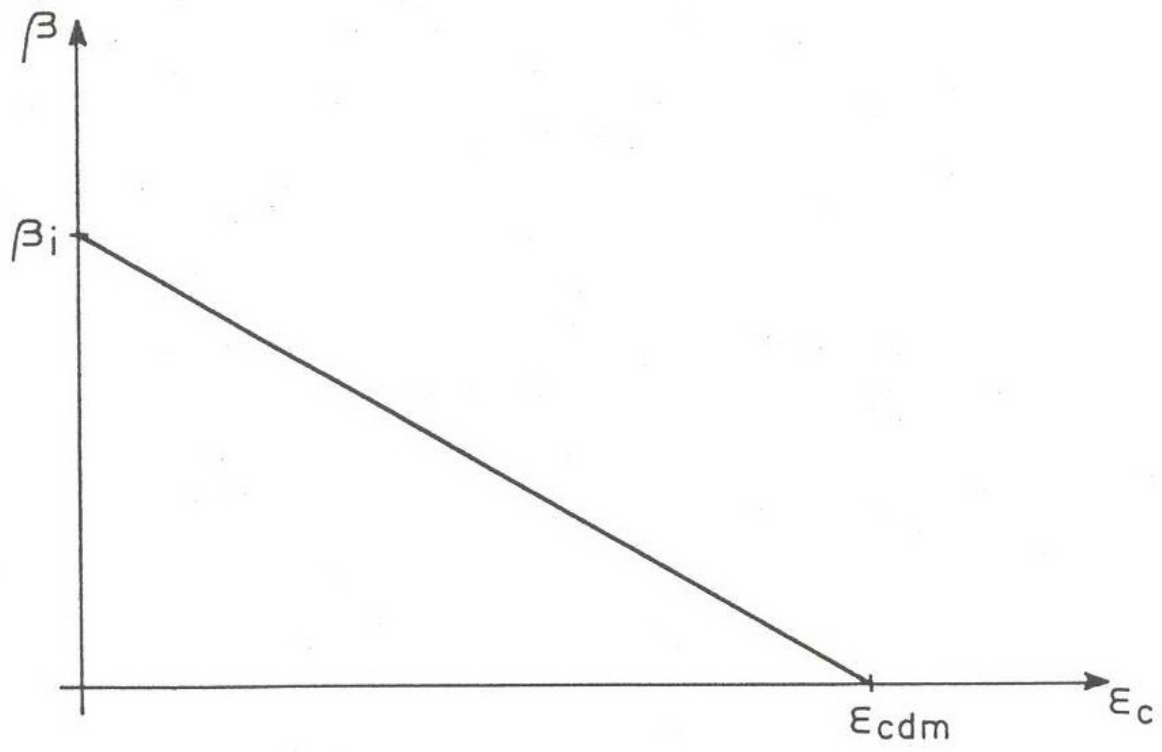

4

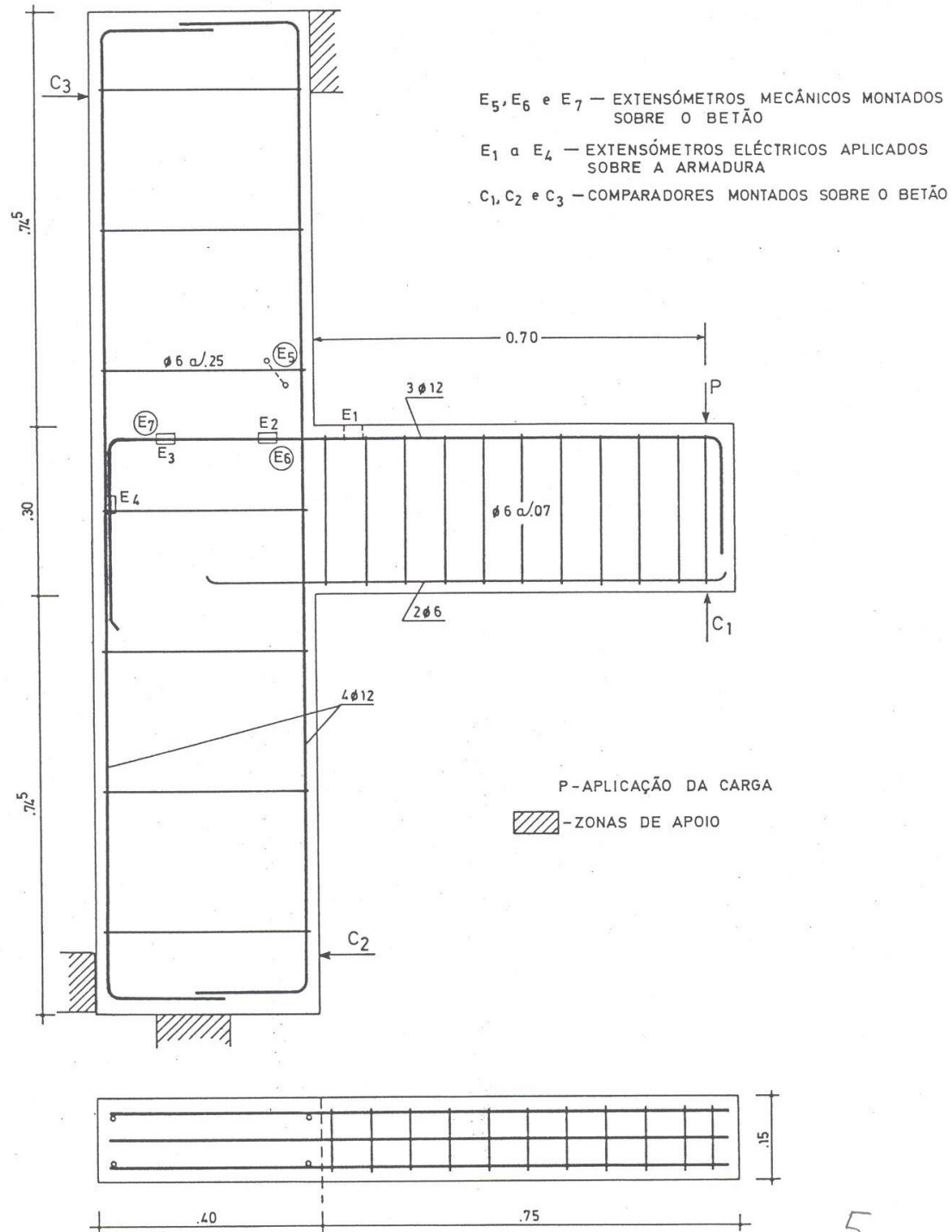

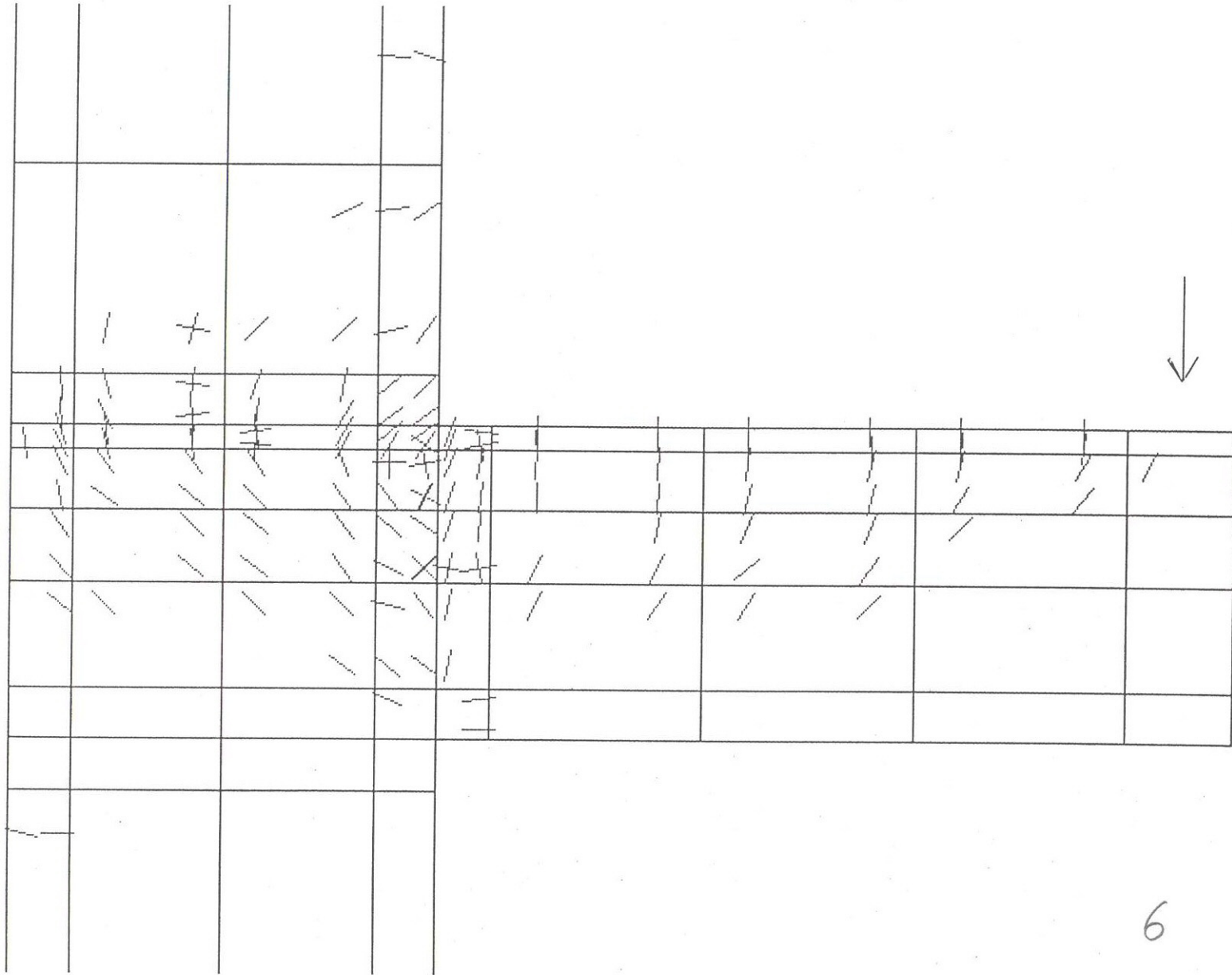

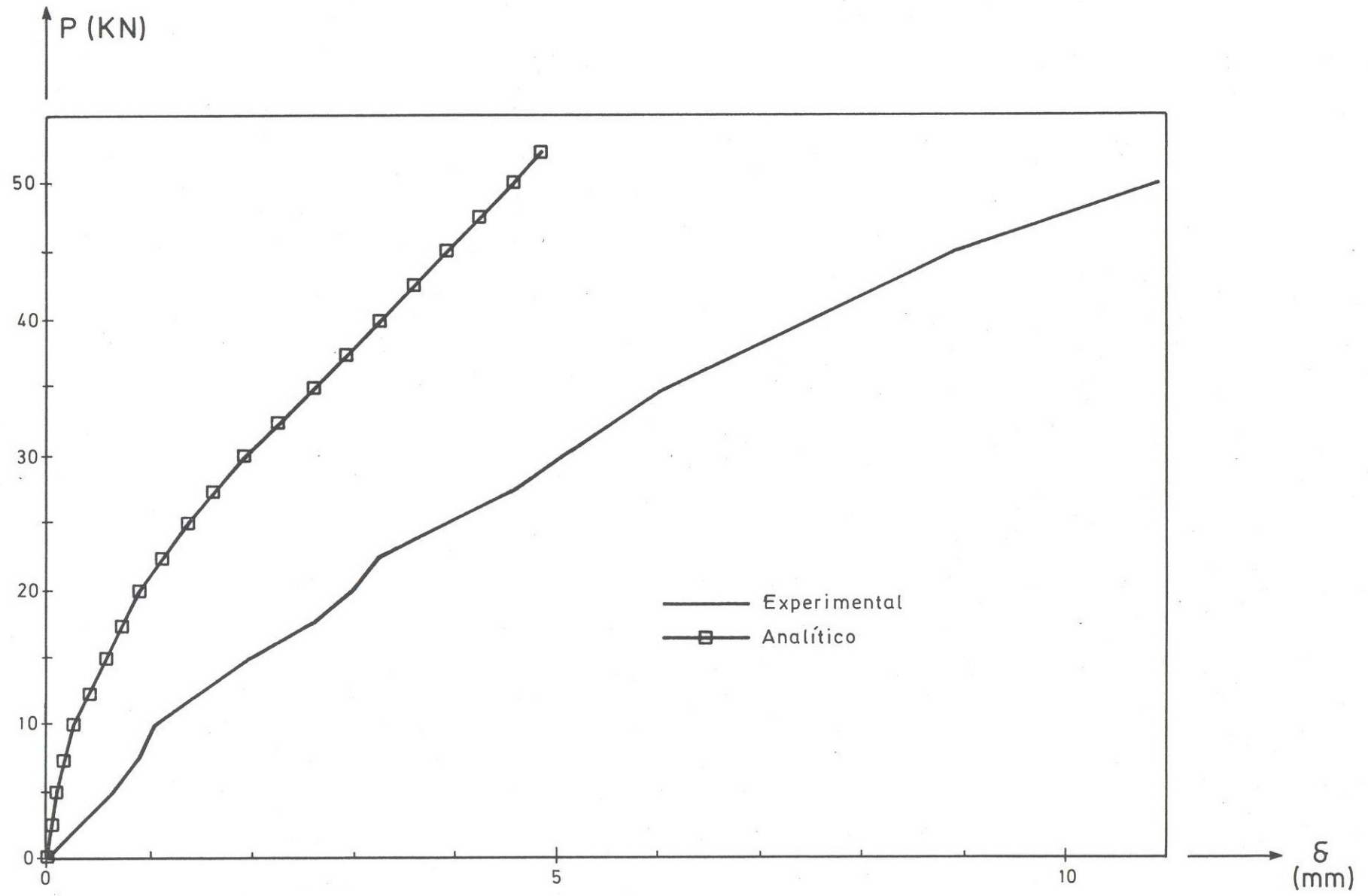

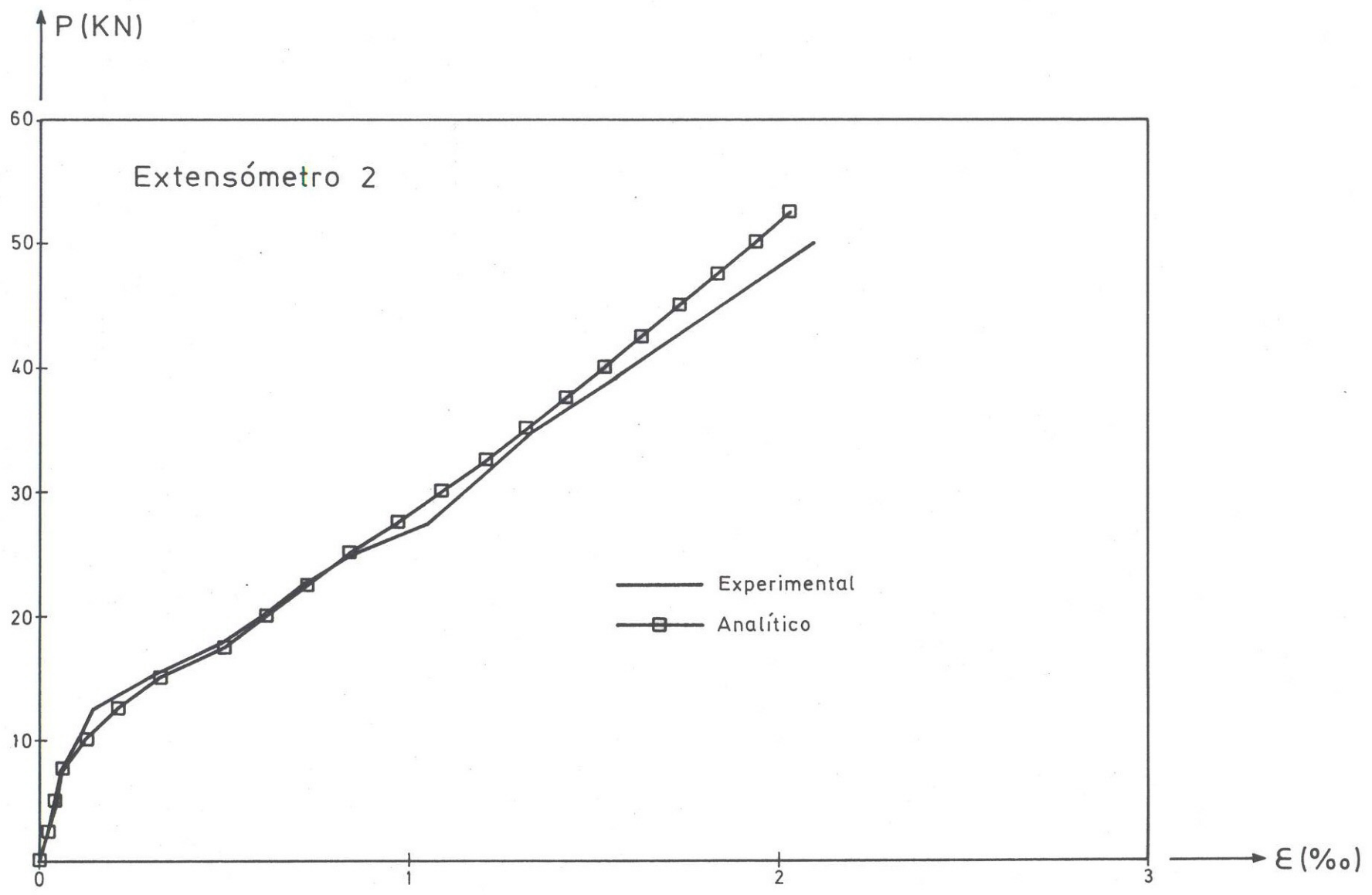

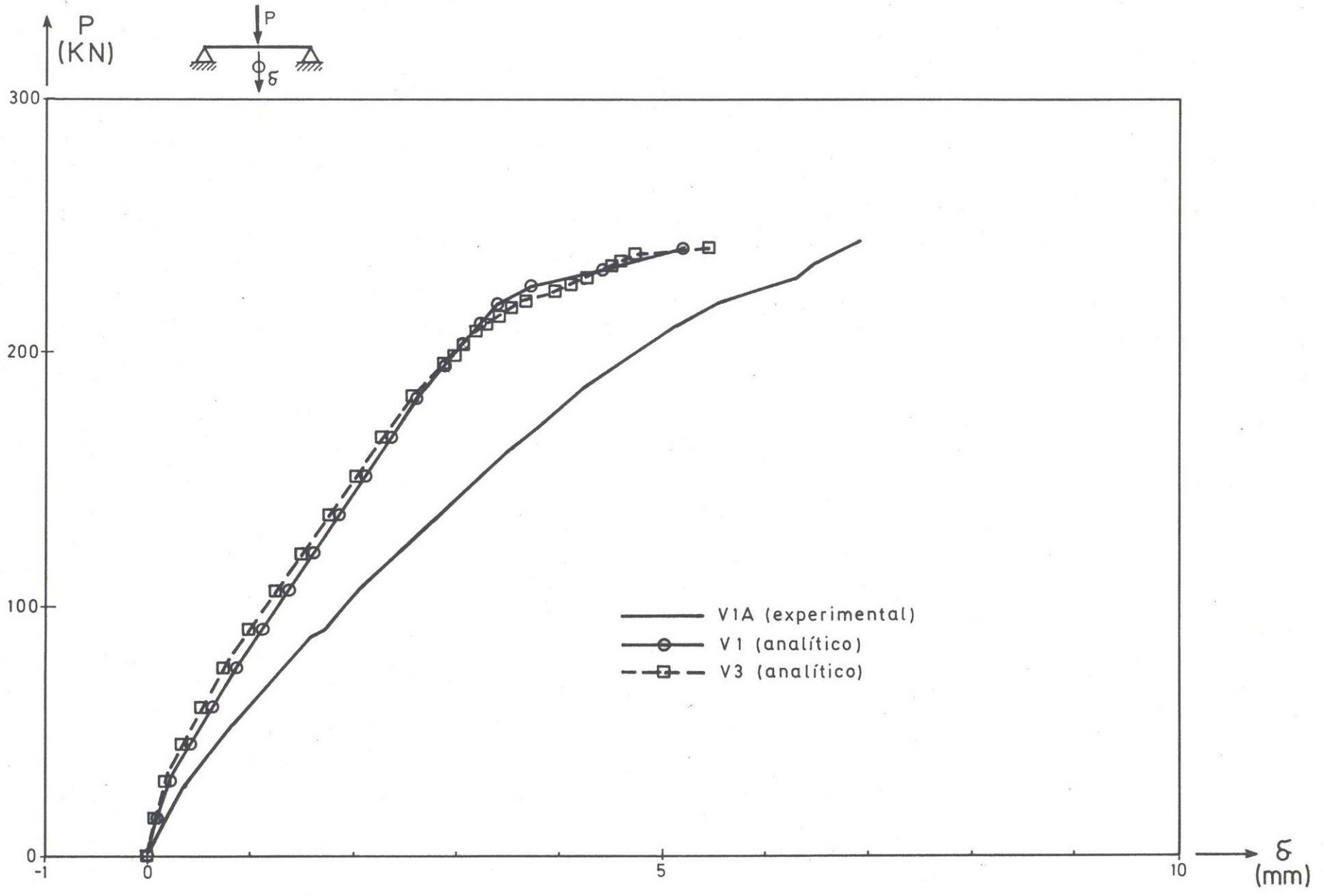

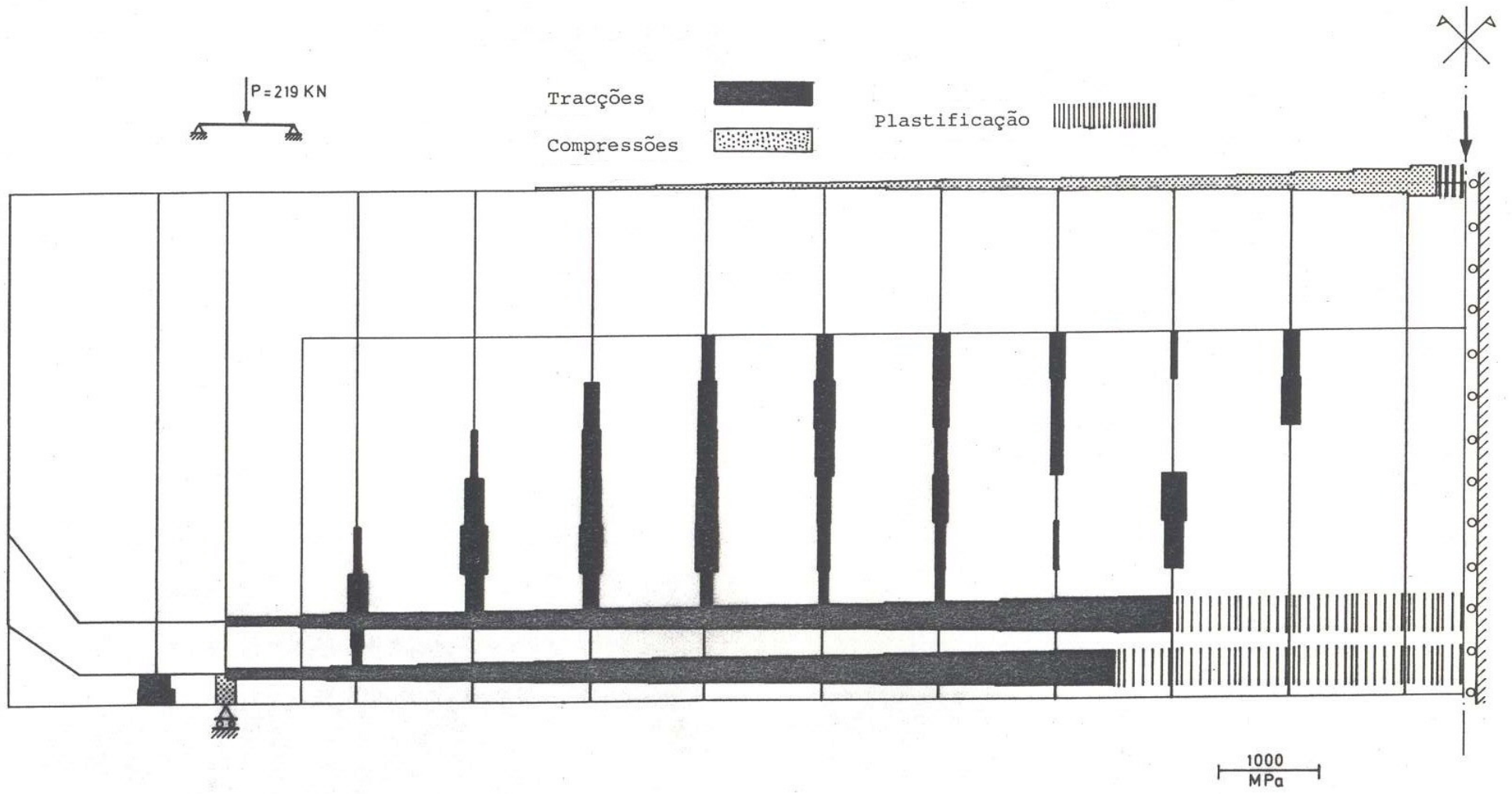

10

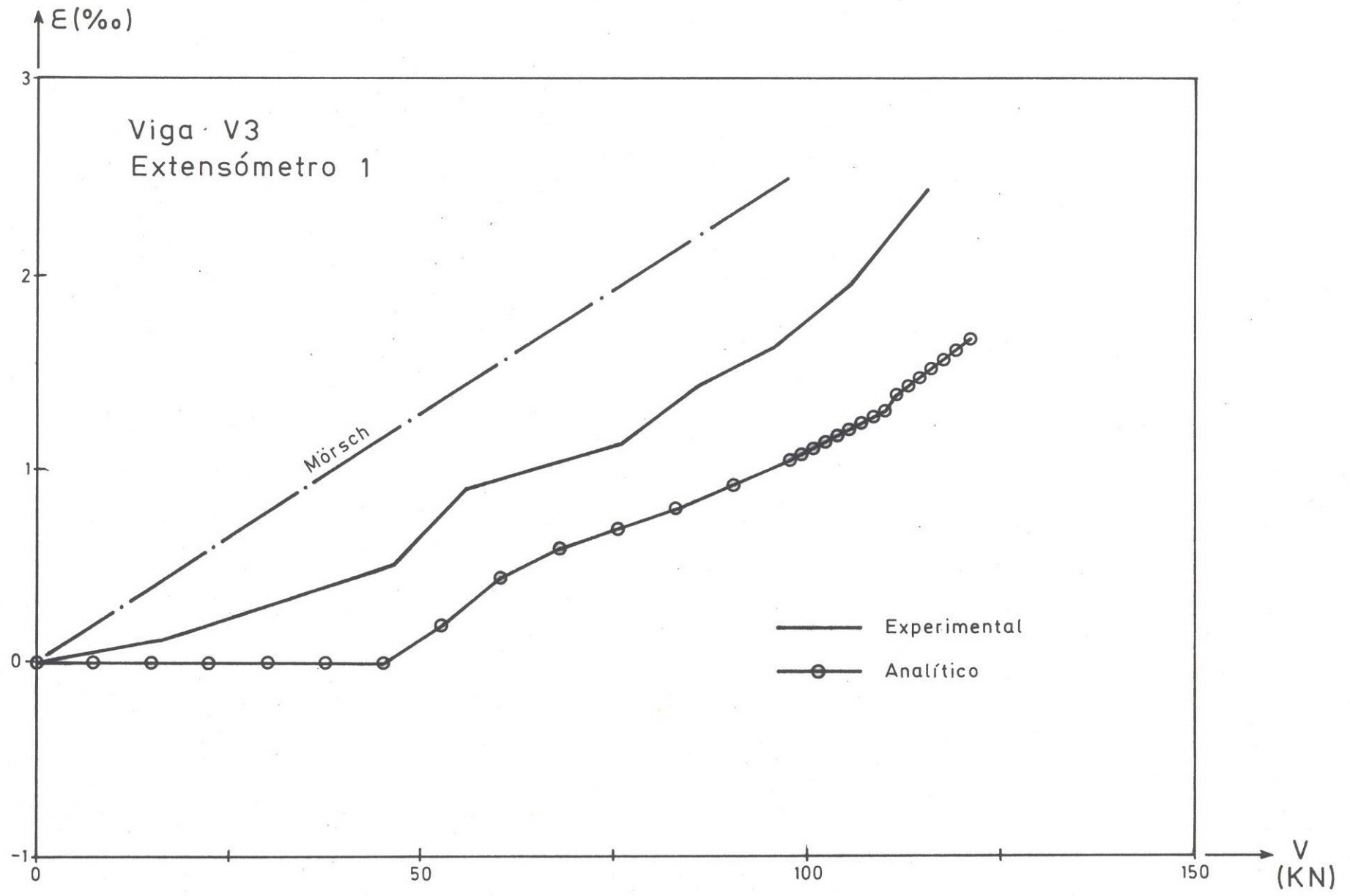

11

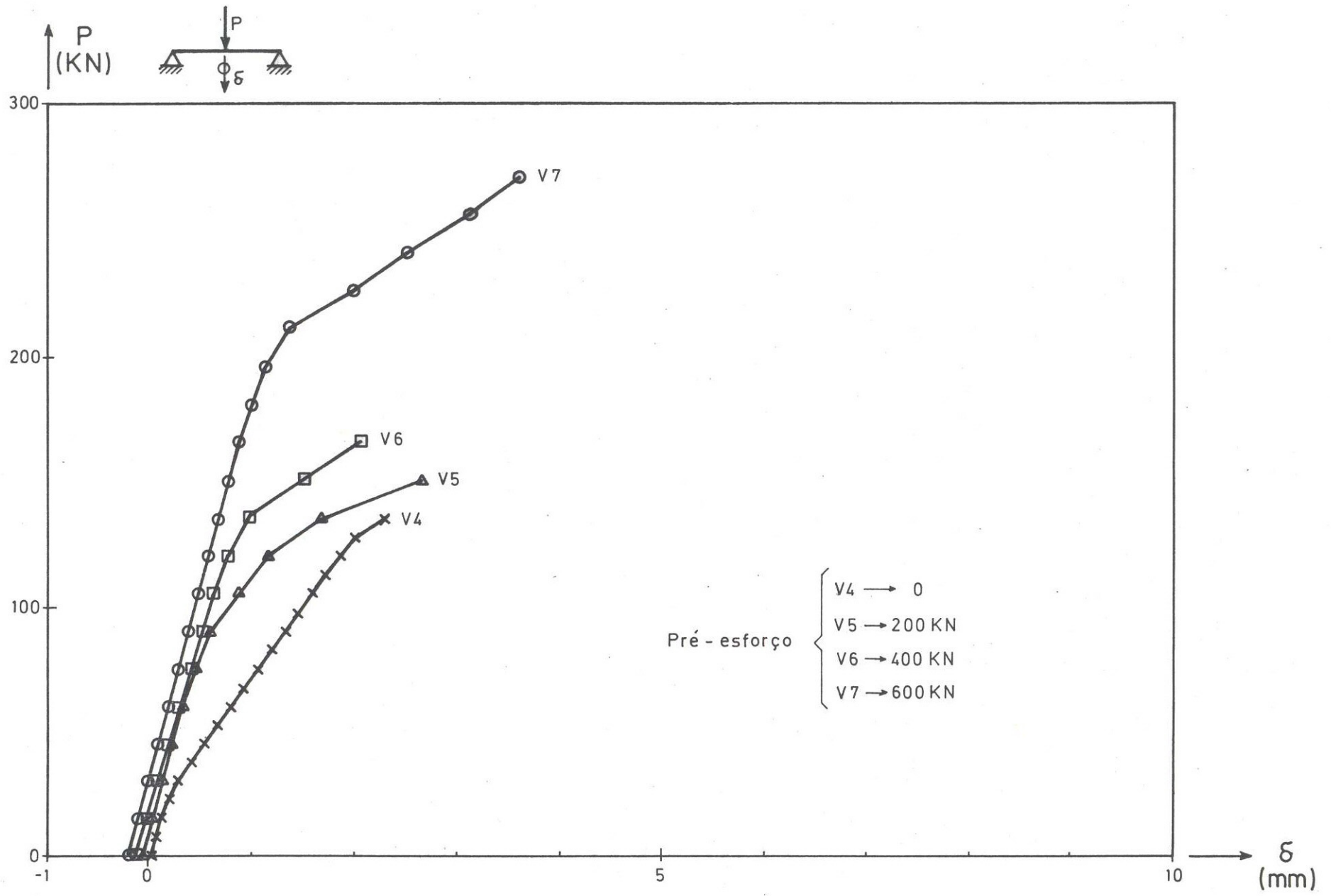

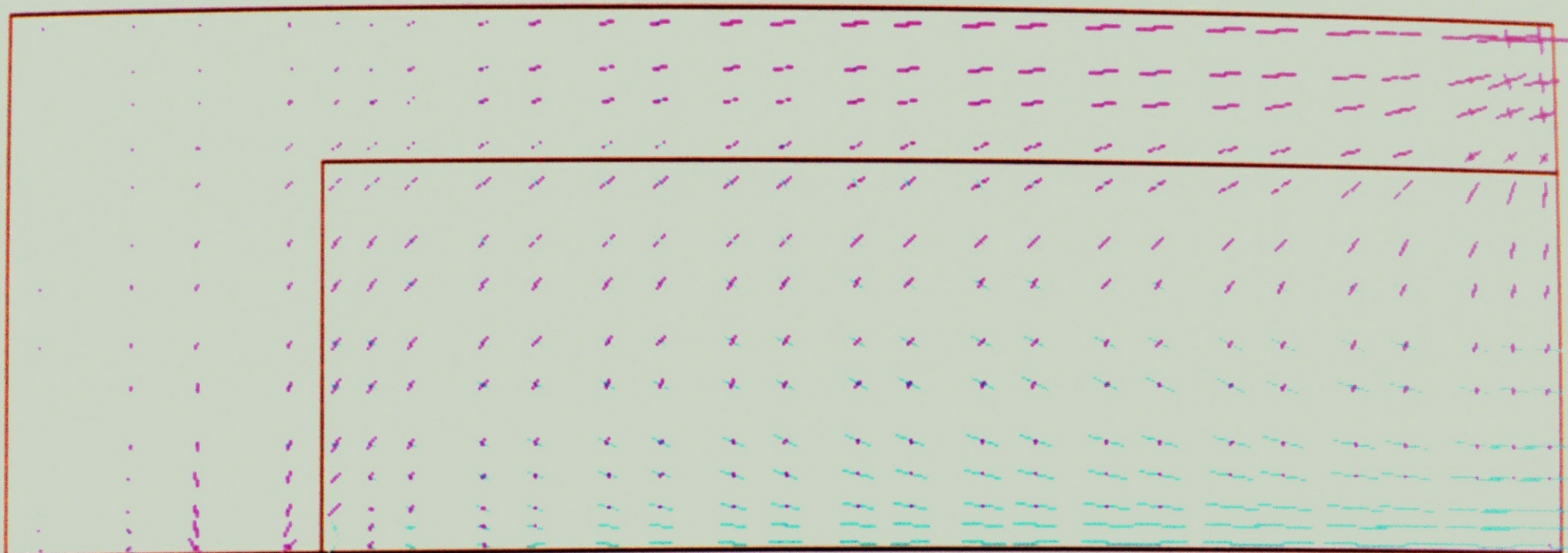

INC. N. 1

I¹

13

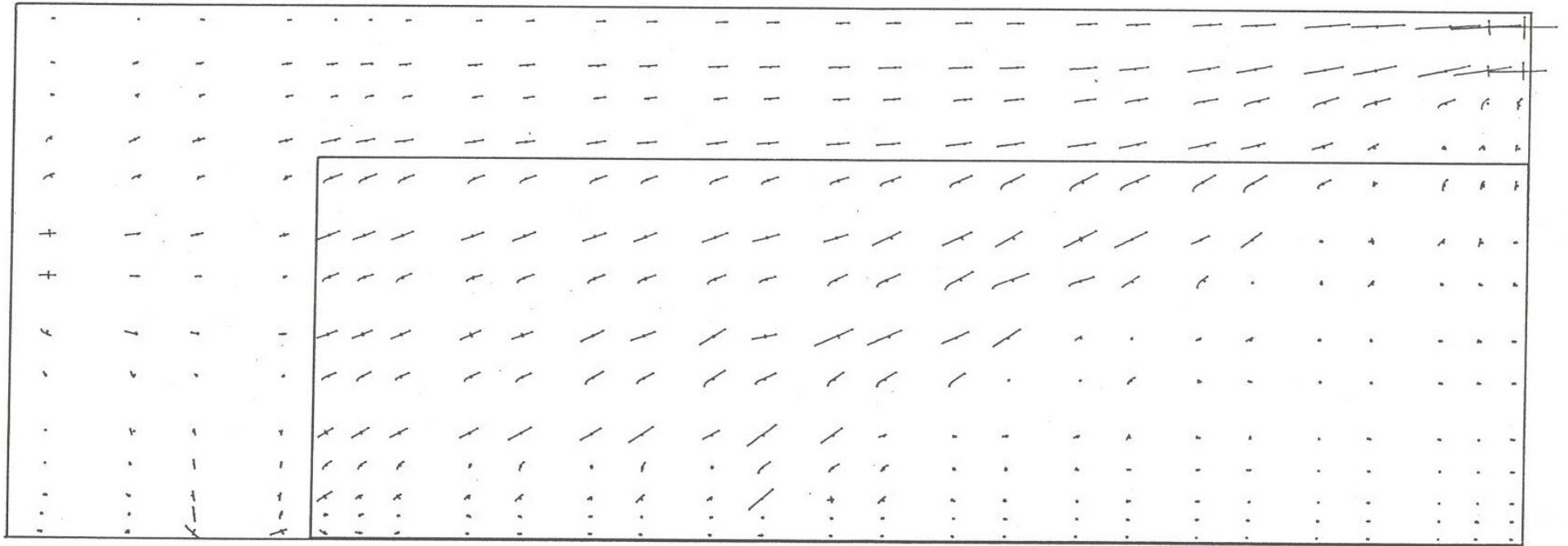

20

14

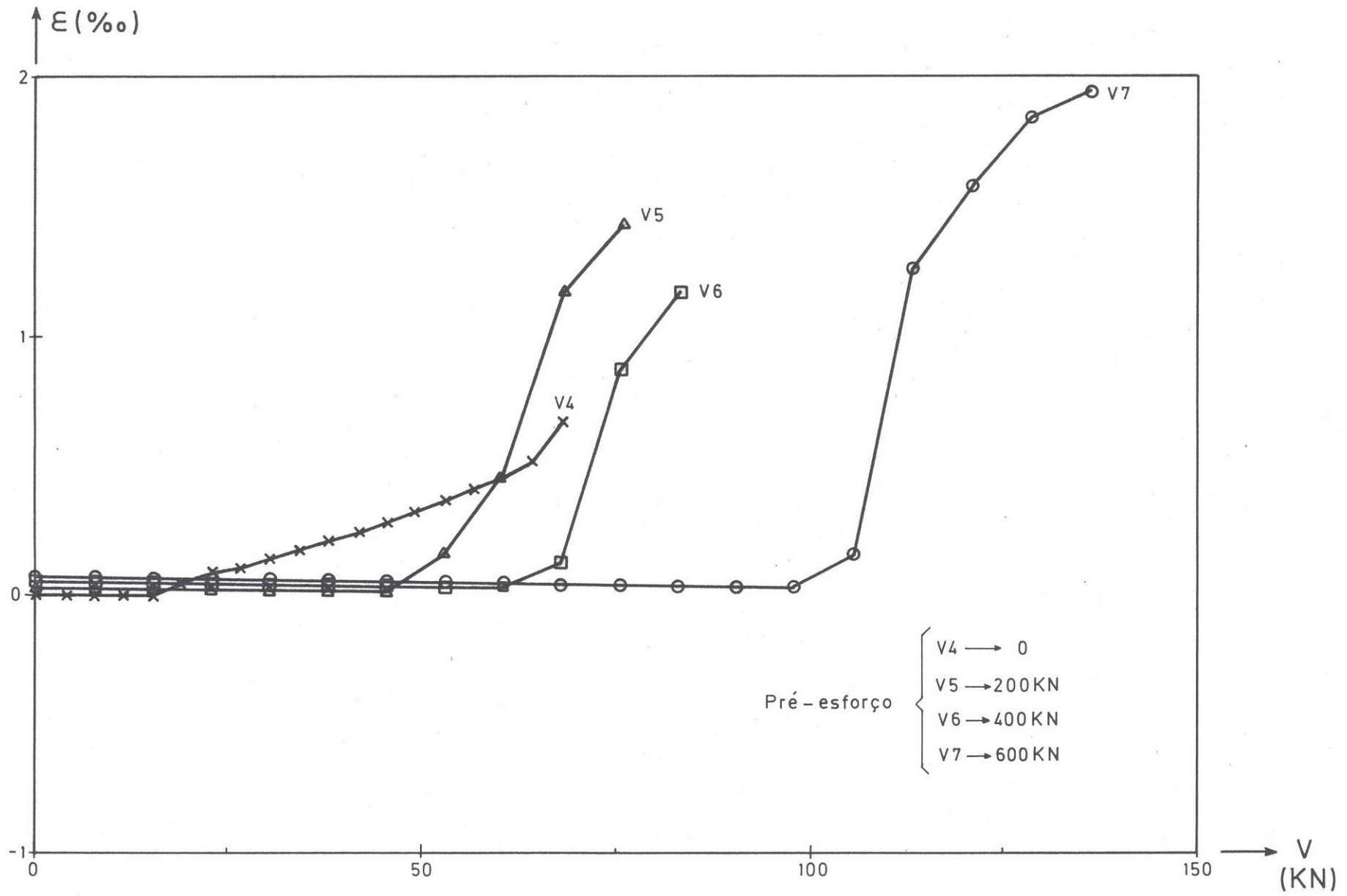

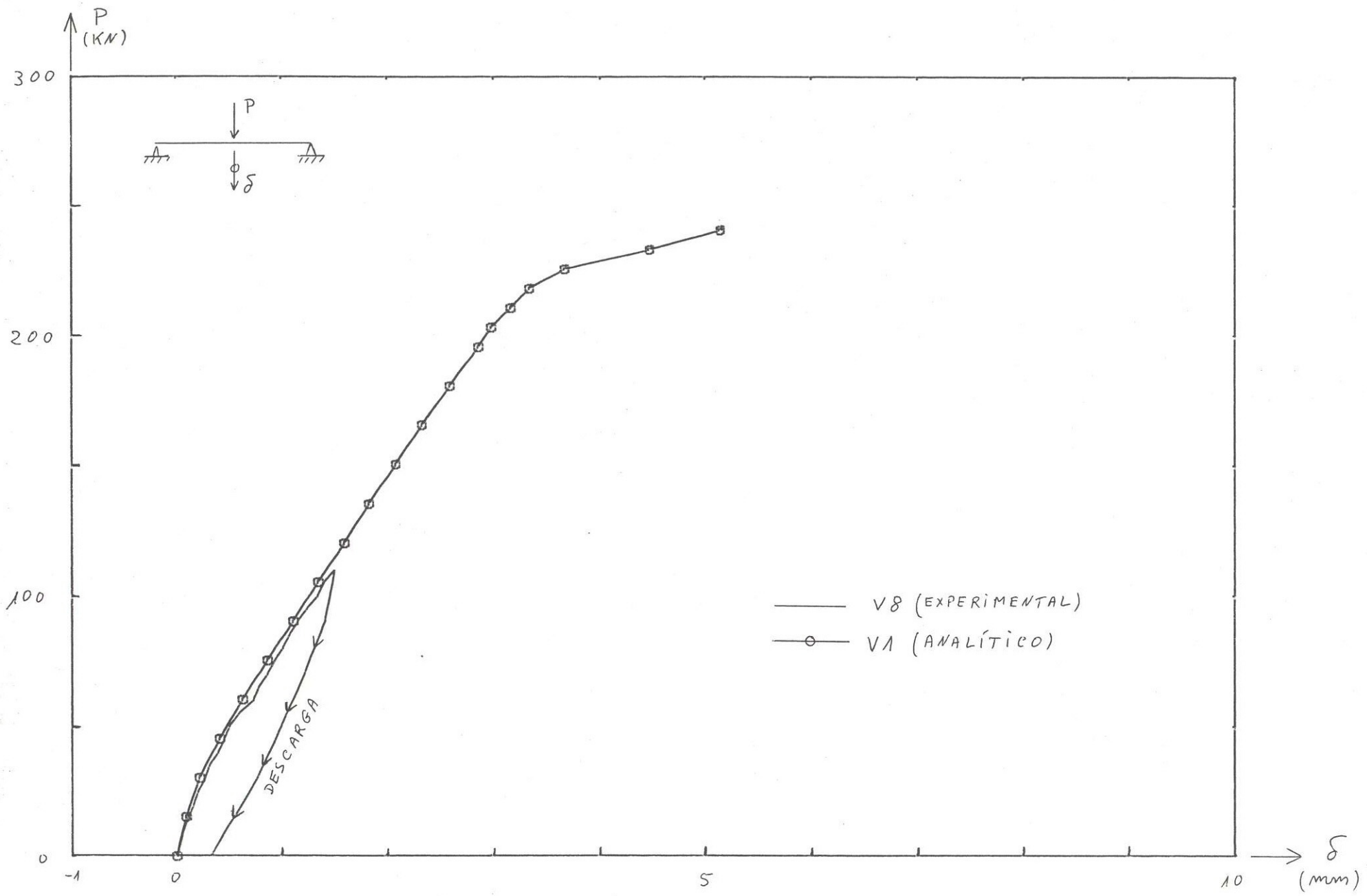

CONCLUSOES

- AFERICAO DE MOD. MAT. COM ENSAIOS EXPERIMENTAIS

- VOLUME DE INFORMACAO FORNECIDA PELO MOD. MAT.

- POSSIBILIDADE DE UTILIZAR PROPRIEDADES BEM DEFINIDAS

- MODELOS MATEMATICOS NO PROJECTO